

Semantics-Aware Synchronization Determinism and Beyond

Qi Zhao

North Carolina State University

The Non-Deterministic Nature of Multithreaded Programs

- Hard to get right
 - A large number of possible schedules
 - Different executions can get different results
 - Difficult to write, test, debug, and verify
- Suffer from concurrency issues

Existing techniques

Bug Detection and Fixing

Automatic Bug Detection

Automatic Bug Fixing

Reduce or Eliminate Non-Determinism

Record and Replay

Deterministic Multithreading (DMT)

Deterministic Multithreading (DMT)

- Ensures that executions of the same program with the same input will have the same schedule
- Two levels of determinism guarantees
 - Weak determinism:
 - Only enforces synchronization determinism
 - Strong determinism:
 - Further enforces memory-access determinism

Synchronization Determinism

- Currently not the research focus of DMT systems
- Why synchronization determinism?
 - Reduces the number of remaining races
 - Feasible to check all remaining schedules
 - Serves as a basis for strong determinism

Synchronization Determinism

- Turn-based mechanism

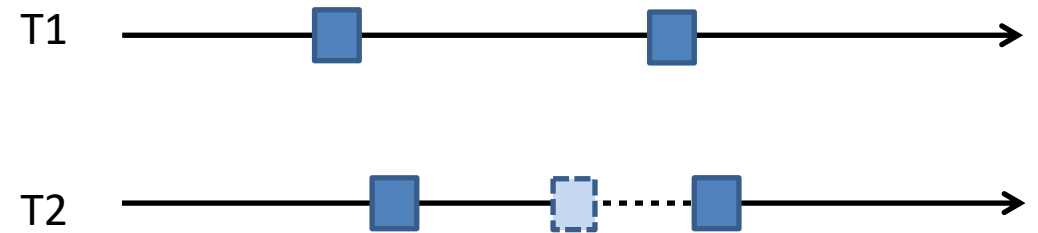

Synchronization Determinism

- Turn-based mechanism
- Different scheduling policies

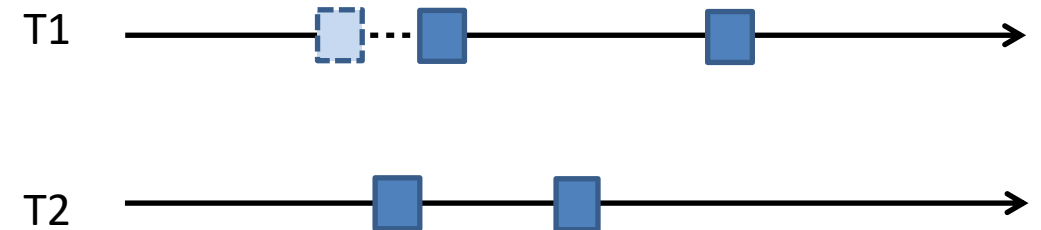

Synchronization Determinism

- Turn-based mechanism
- Different scheduling policies

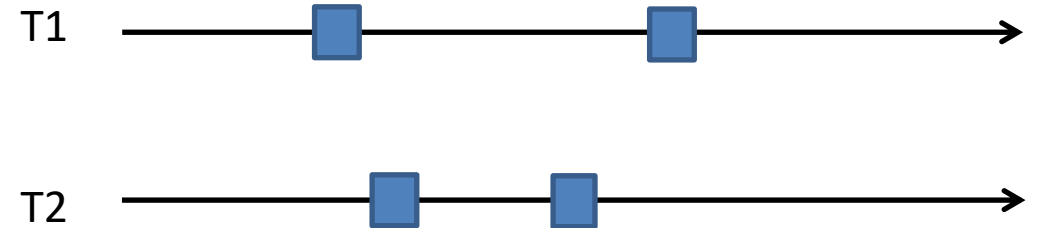

Two Types of Scheduling Policies

Logic clock

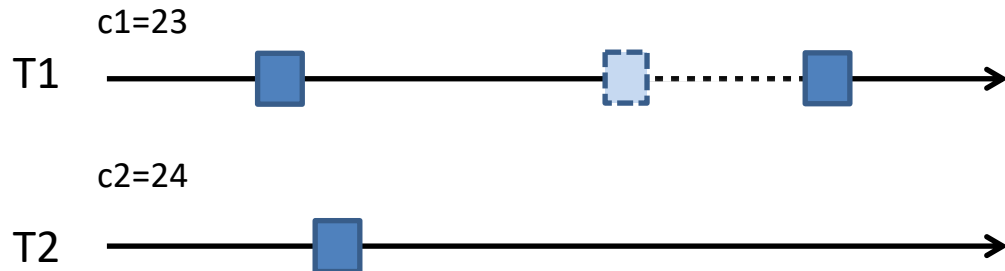

Round robin

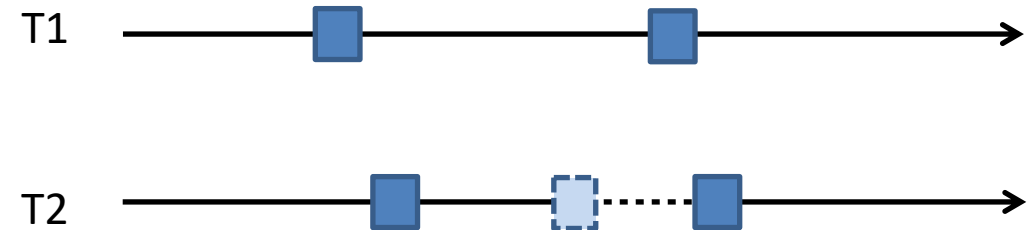

Metrics of Scheduling Policies

- Performance
 - What is the overhead caused by DMT systems
- Stability
 - How frequent will a scheduling policy reuse schedule
- Fairness
- Deadlock free

Two Types of Scheduling Policies

Logic clock



Performance 😊

Stability 😞

Round robin

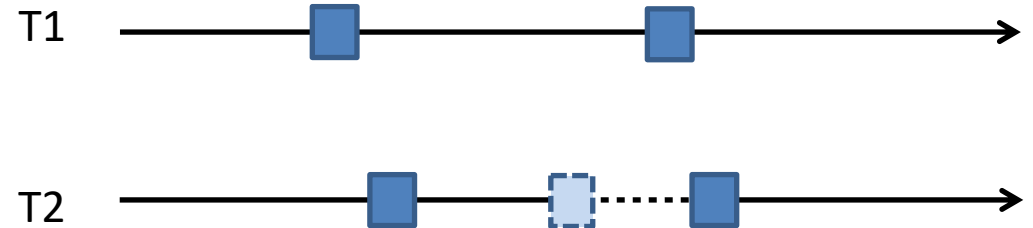

Stability 😊

Performance 😞

Round-robin Example

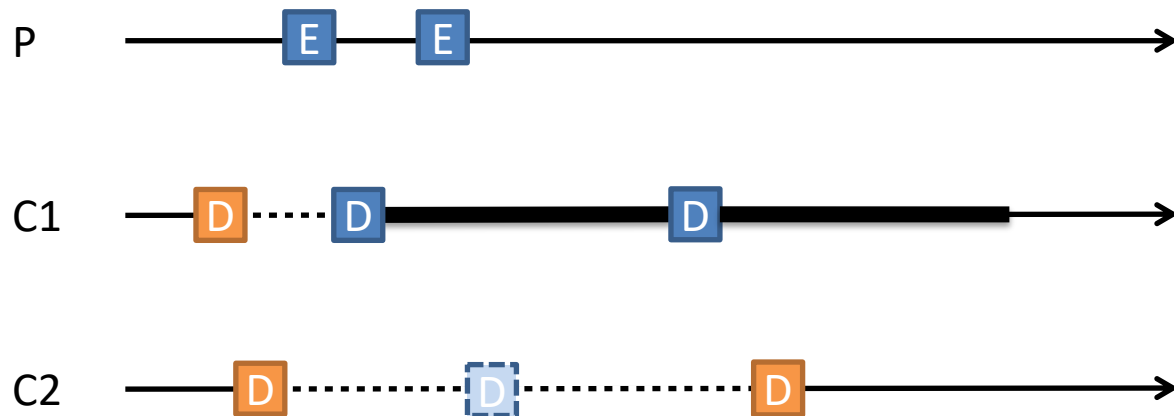

```
void producer(void *arg){
    ...
    ...
    for (i=0; i<nblocks; ++i){
        char *block = read_block(i);
        enqueue(q, block);
    }
    ...
}
```

```
void *consumer(void *arg) {
    ...
    while(1) {
        char *block = dequeue(q);
        ...
        ...
        compress(block);
    }
}
```

Parrot's Soft Barrier

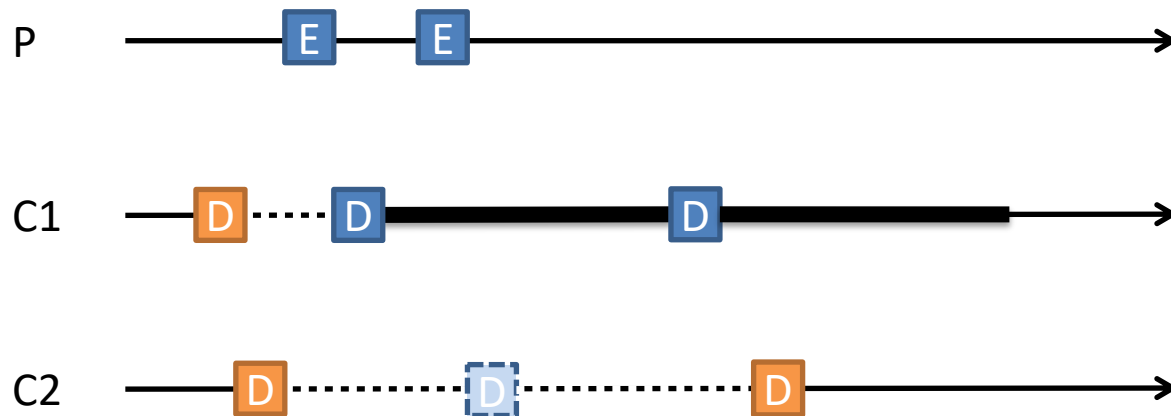

```
void producer(void *arg){
    soba_init(number_of_consumers)
    ...
    for (i=0; i<nblocks; ++i){
        char *block = read_block(i);
        enqueue(q, block);
    }
    ...
}
```

```
void *consumer(void *arg) {
    ...
    while(1) {
        char *block = dequeue(q);
        ...
        soba_wait()
        compress(block);
    }
}
```

Parrot's Soft Barrier

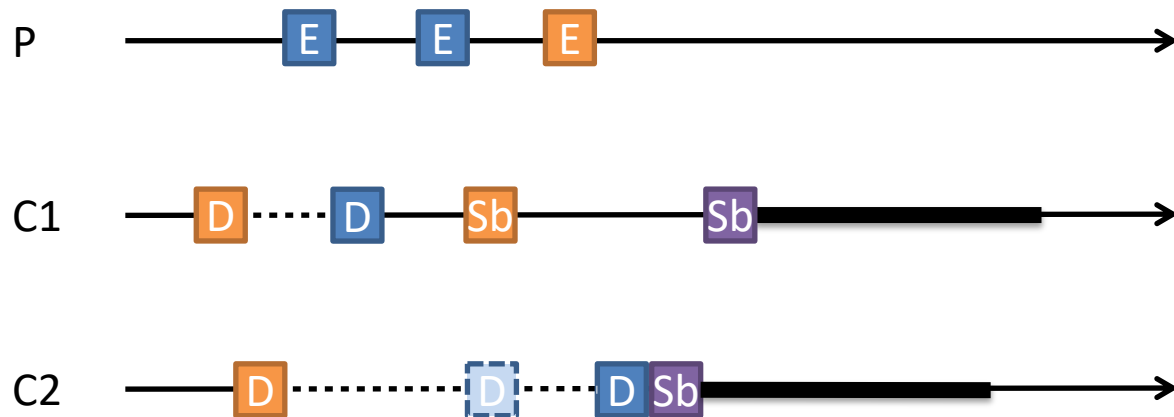

```

void producer(void *arg){
    soba_init(number_of_consumers)
    ...
    for (i=0; i<nblocks; ++i){
        char *block = read_block(i);
        enqueue(q, block);
    }
    ...
}

```

```

void *consumer(void *arg) {
    ...
    while(1) {
        char *block = dequeue(q);
        ...
         soba_wait()
        compress(block);
    }
}

```

Parrot's Soft Barrier

Problems with Soft Barriers

- Extra manual effort
- Can sometimes be difficult to place
- Need to be maintained

```
void producer(void *arg){
    soba_init(number_of_consumers)
    ...
    for (i=0; i<nblocks; ++i){
        char *block = read_block(i);
        enqueue(q, block);
    }
    ...
}
```

```
void *consumer(void *arg) {
    ...
    while(1) {
        char *block = dequeue(q);
        ...
        soba_wait()
        compress(block);
    }
}
```



QiThread

- BoostBlocked
- CreateAll
- CSWhole
- WakeAMAP
- BranchedWake
- Our insight: By leveraging synchronization semantics, we can not only remove the need of manual annotations, but also achieve good performance and schedule stability

BoostBlocked

Prioritize threads woken up from the blocked state

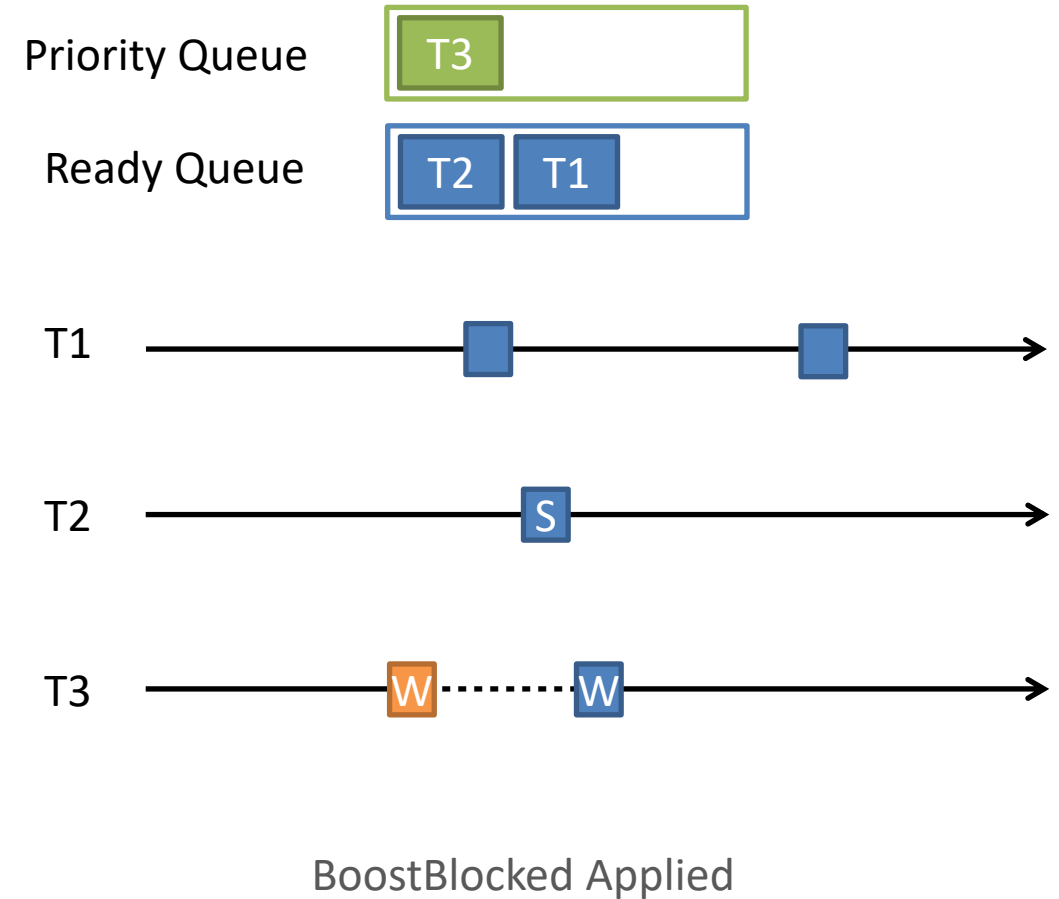
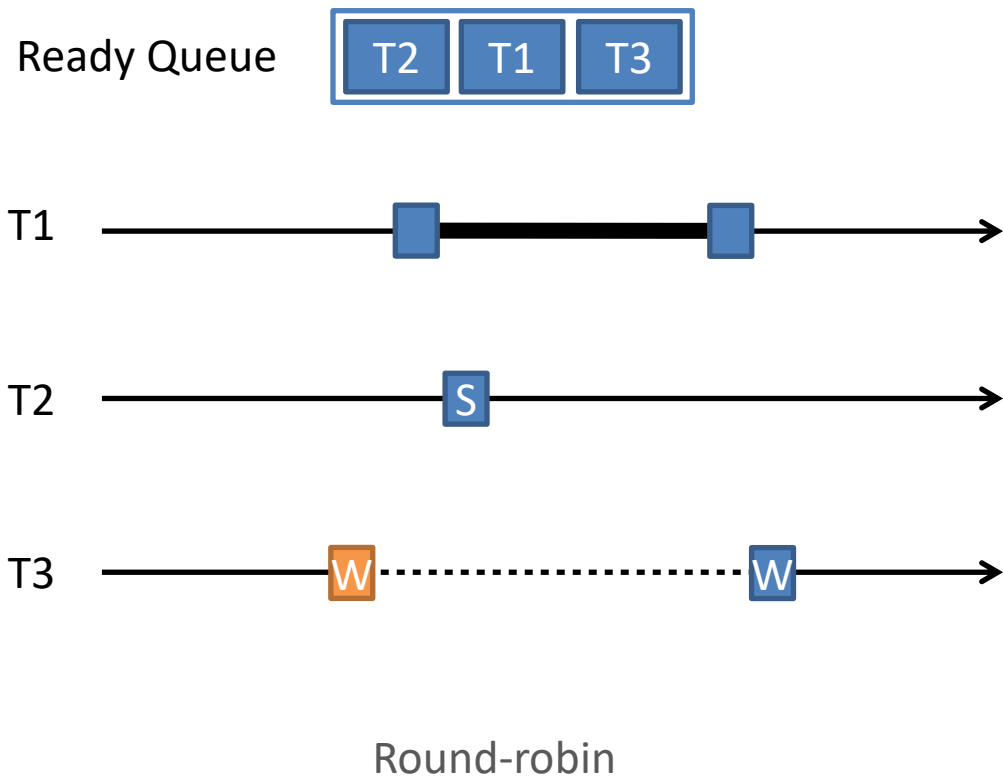

CreateAll

Schedule multiple pthread_create together

```

Parent thread
void parent_main(...){
    for (i=0;i<nThreads;i++)
        pthread_create(..., ...,
                       child_main,...);
}

Child thread
void child_main(...){
    thread_begin();
    // no synchronization
    thread_end();
}
    
```

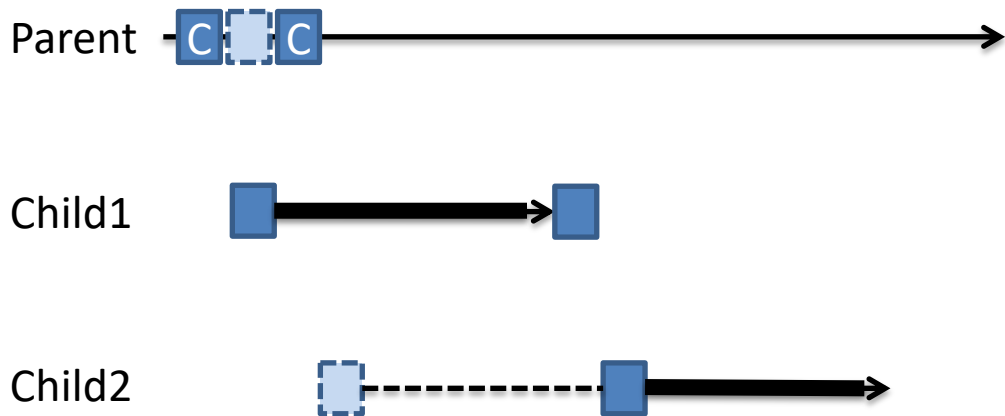

Round-robin

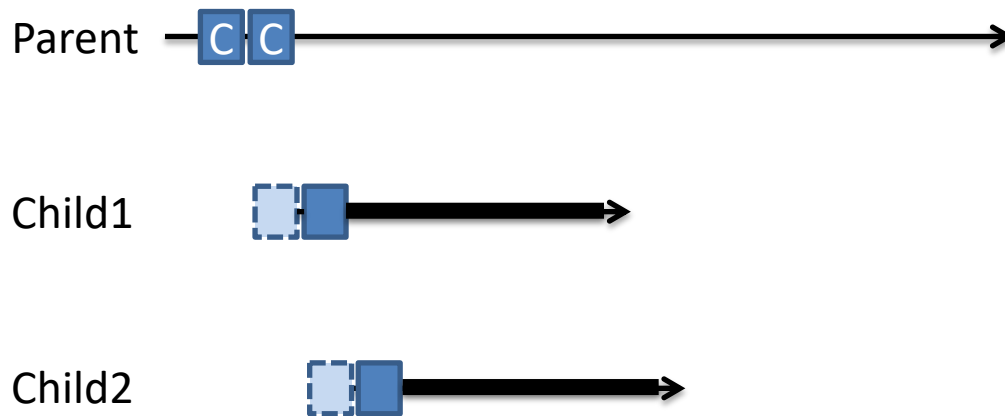

CreateAll Applied

CSWhole

Schedule a critical section as a whole

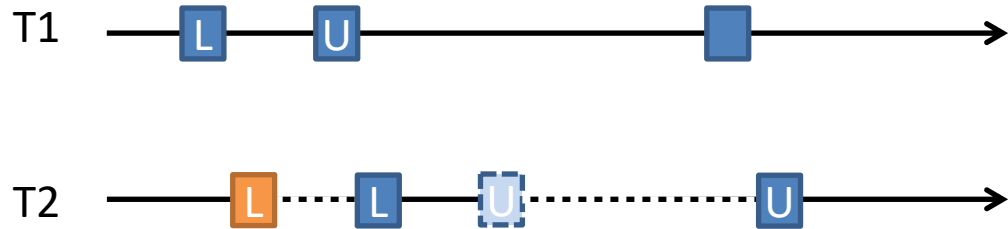

Round-robin

```

...
pthread_mutex_lock(&m);
counter++;
pthread_mutex_unlock(&m);
...

```

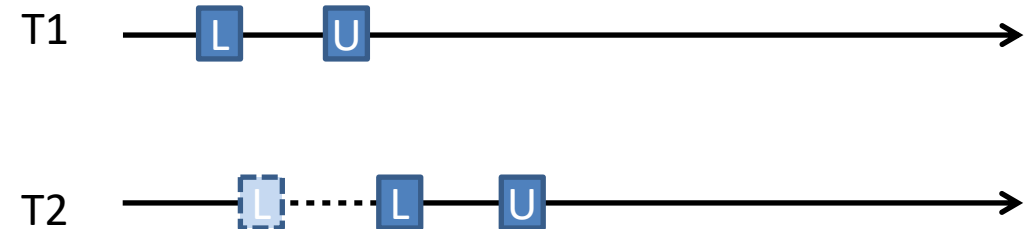

CSWhole applied

WakeAMAP

Wake up as many threads as possible

```
void producer(void *arg){
    while(cond1) {
        sync();
        sem_post(s);
        ...
    }
}
```

```
void consumer(void *arg) {
    ...
    sem_wait(s);
    do_work();
    ...
}
```

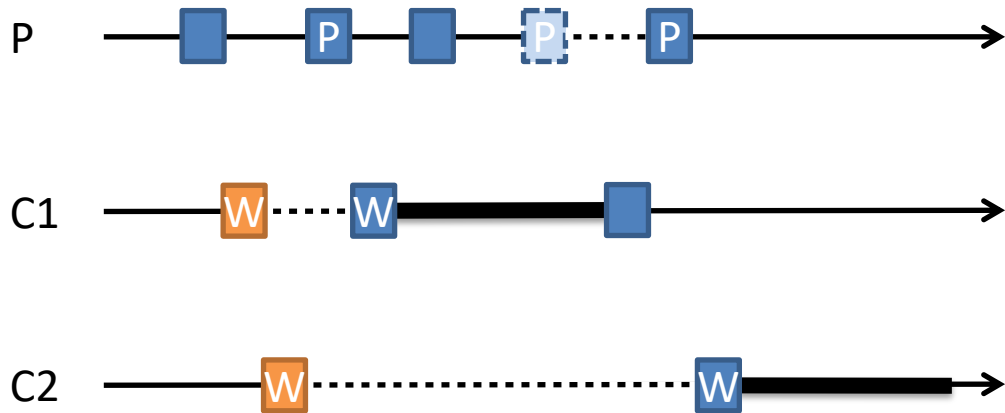

Round-robin

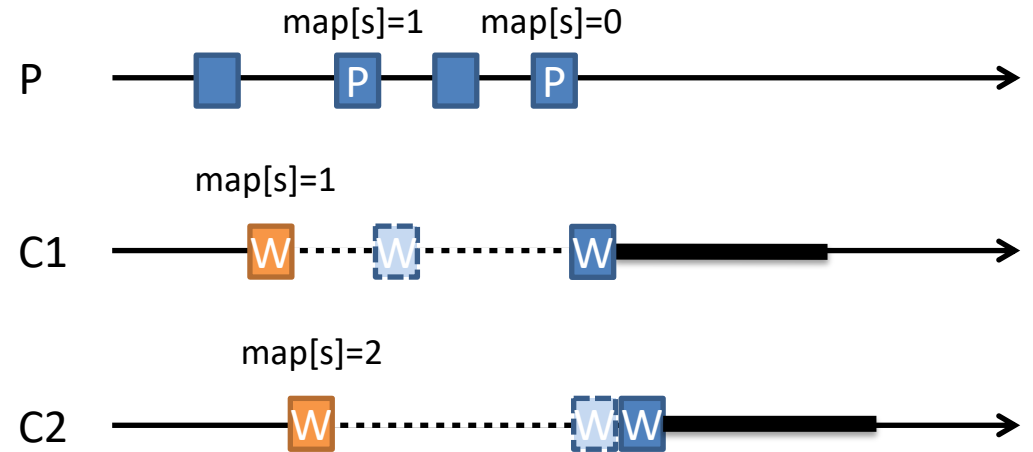

WakeAMAP applied

BranchedWake

Handle threads that have wake-up synchronization in a branch

```

Multiple Post threads:
■ sync();
if (isLastPostThread)
// The last thread posts
■ P
■ do_work();
■ sync();
    
```

```

Waiting thread:
■ W sem_wait(s);
do_work();
■ sync();
    
```

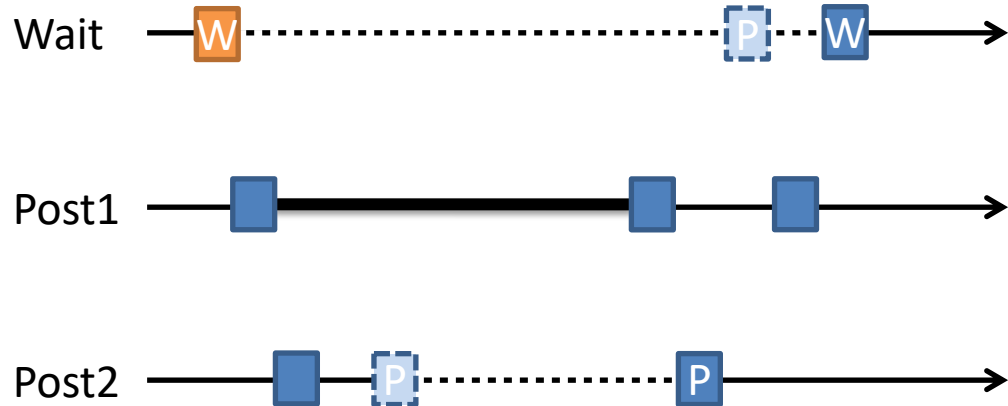

Round-robin

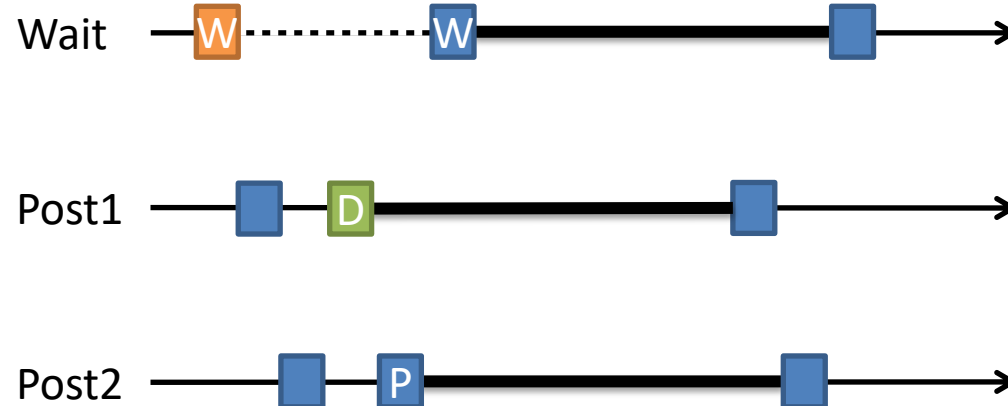

BranchedWake & BoostBlocked

Evaluation

- Performance: all 108 programs
 - Used the same thread count as in Parrot
 - Parrot w/ soft barrier hint and QiThread w/ all policies enabled

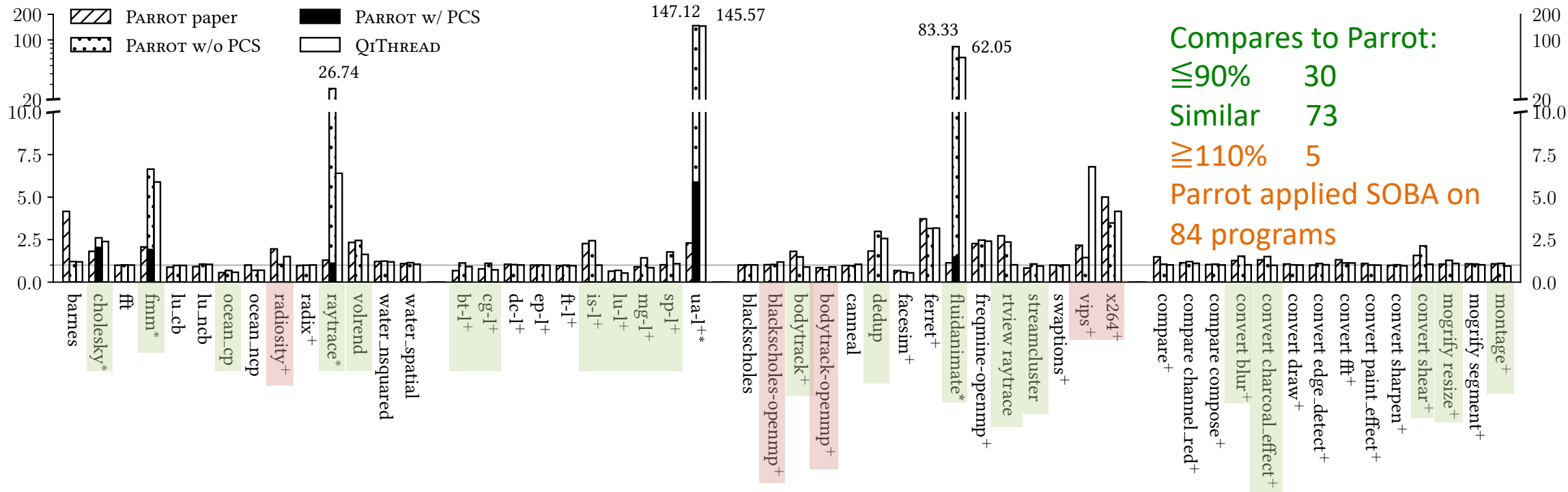

Compares to Parrot:
 $\leq 90\%$ 30
 Similar 73
 $\geq 110\%$ 5
 Parrot applied SOBA on
 84 programs

SPLASH-2x

NPB 3.3.1

PARSEC

ImageMagick

STL libstdc++-v3

Phoenix 2

Real World Programs

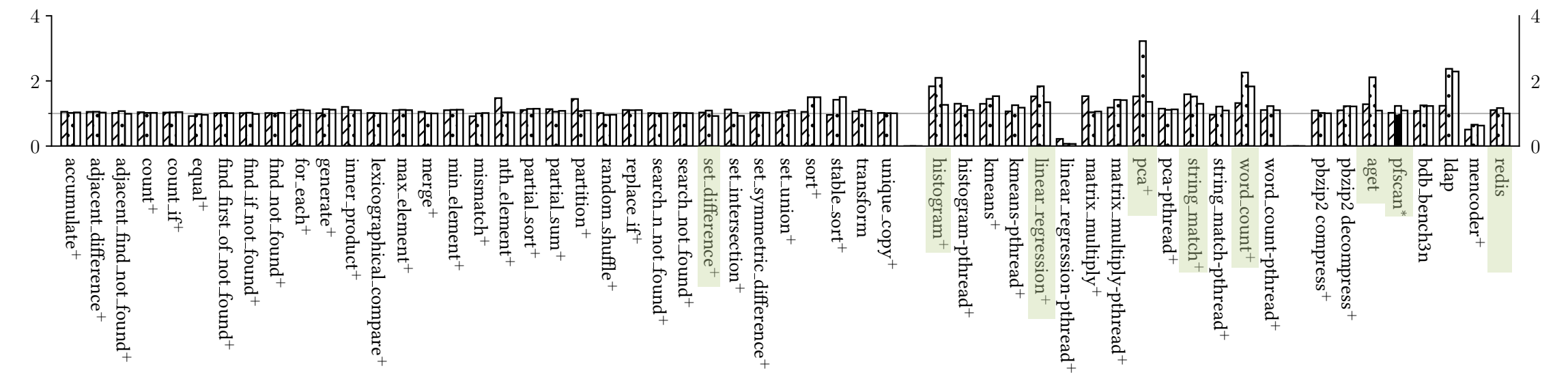

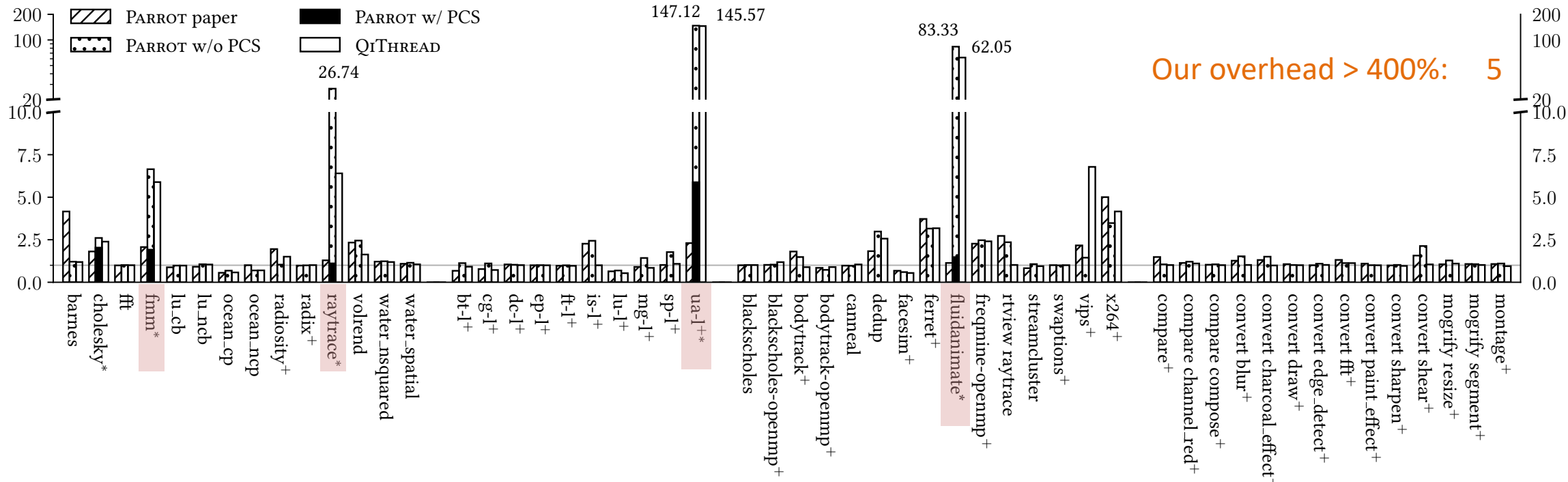

SPLASH-2x

NPB 3.3.1

PARSEC

ImageMagick

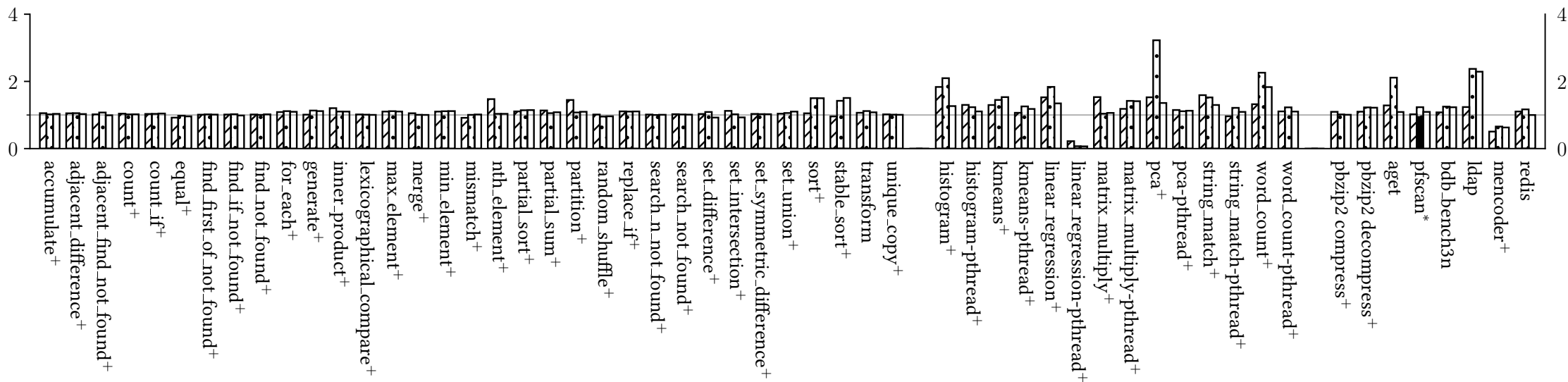

STL libstdc++-v3

Phoenix 2

Real World Programs

Future Work

- High-level thread role analysis
 - Analyze synchronization relationship and data dependencies
 - Model thread role: producer, consumer, pipeline, etc.
 - Prioritize threads which produce data that other threads depends on
 - Instrument role changing annotations

Summary

- QiThread
 - Five semantics-aware policies on top of round-robin
 - No manual performance hints needed
 - Widely effective
- Efficient and stable synchronization determinism can be achieved by leveraging synchronization semantics
- Future work: scheduling with the understanding of high-level thread roles

Thank you! 😊

Questions